

CASE SEALERS

Competitive Pricing Without Sacrificing Quality

SD-662

Semi-Automatic
Case Sealer

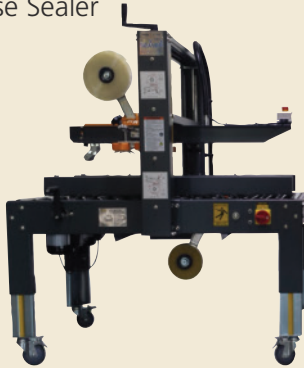

TB-652

Semi-Automatic
Case Sealer



TS-654

Semi-Automatic
Case Sealer



SR-655

Semi-Automatic
Random Case
Sealer



SD-657

Fully Automatic
Case Sealer

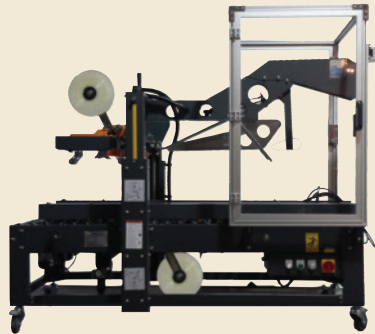

SR-659

Fully Automatic
Random Case
Sealer

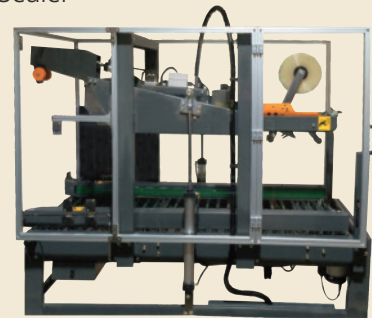

PIRANHA TAPE HEAD

Piranha

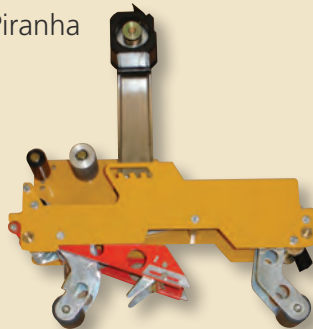

*Drop-in replacements
for most major brand
case sealers and
erectors.*

Taking a bite out of the competition.
Available in Standard Paint or Stainless Steel.

CE-563

Semi-Automatic
Case Erector/
Pack Station



SEMI-AUTOMATIC CASE SEALER

SD-662 – UNIFORM SIZES – SIDE BELT DRIVES

For applications where previously erected cases are loaded and flaps are manually closed.

- Plug-in Operation
- Dual Masts with twin lead screws for stability
- Precise Top and Bottom sealing
- Side Mounted Compression Rollers for tight seals
- Heavy Duty Side-Belt Drives ensure square cases
- Adjustable Leg Supports
- Easy case-size change-over – two crank handles
- Piranha Tape Heads for accurate and consistent sealing

SD-662

Speed: Up to 2,400 Cases/Hour (65 fpm)
Case Length: 6" minimum – no maximum
Case Width: 4" minimum – 20" maximum
Case Height: 3" minimum – 20" maximum

Electrical: 110VAC-1PH-60Hz – 10 Amps
Air: None
Dimensions: 51.5" L x 38" W x 56" H
Weight: 300 lbs

Note: If the case height exceeds its length, it may not be suitable for this machine.

Capacity for larger cases. Please call or e-mail case sizes.

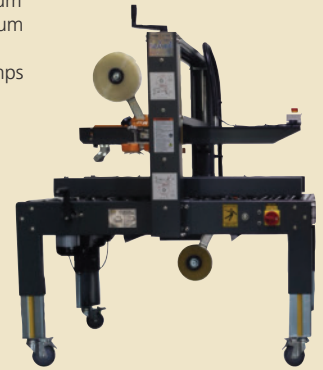

SEMI-AUTOMATIC CASE SEALER

TB-652 – UNIFORM SIZES – TOP and BOTTOM DRIVES

Extremely versatile for standard sized cases. Four belts positively control cases. Manual flap folding.

- Plug-in Operation
- Dual Masts with twin lead screws for stability
- Precise Top and Bottom sealing
- Dual, Top Mounted Belt Drives for top control
- Heavy Duty Side-Belt Drives ensure square cases
- Side Mounted Compression Rollers for tight seals
- Adjustable Leg Supports
- Easy case-size change-over – two crank handles
- Piranha Tape Heads for accurate and consistent sealing

TB-652

Speed: Up to 2,400 Cases/Hour (65 fpm)
Case Length: 6" minimum – no maximum
Case Width: 7" minimum – 20" maximum
Case Height: 4.5" minimum – 20" maximum

Electrical: 110VAC-1PH-60Hz – 10 Amps
Air: None
Dimensions: 40" L x 31" W x 50-65" H
Weight: 300 lbs

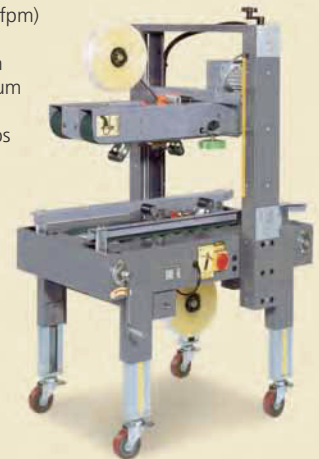

FULLY AUTOMATIC CASE SEALER

SD-657 – UNIFORM SIZES

For applications where previously erected cases are loaded with product and automated case closing and sealing is required. Features include:

- Plug-in Operation – No operator assistance needed
- Dual Masts with twin lead screws for stability
- Precise Top and Bottom sealing
- Front, Back and Side Flaps Automatically Folded
- Side Mounted Compression Rollers for tight seals
- Heavy Duty Side-Belt Drives ensure square cases
- Adjustable Leg Supports
- Easy case-size change-over – two crank handles
- Piranha Tape Heads for accurate and consistent sealing
- Side Safety Guarding

SD-657

Speed: Up to 700 Cases/Hour (65 fpm belt speed)
Case Length: 6" minimum – 30" maximum
Case Width: 4.75" minimum – 20" maximum
Case Height: 4.5" minimum – 20" maximum

Electrical: 110VAC--60Hz – 10 Amps
Air: 1 SCFM @ 70 psi
Dimensions: 75" L x 38" W x 63" H
Weight: 650 lbs

Note: If the case height exceeds its length, it may not be suitable for this machine.

Capacity for larger cases. Please call or e-mail case sizes.

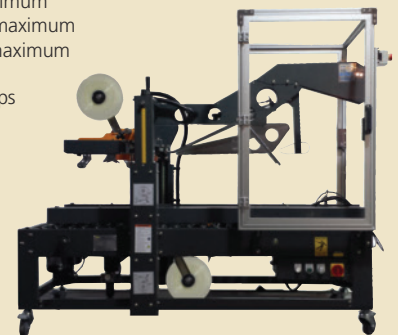

SEMI-AUTOMATIC CASE SEALER

TS-654 – UNIFORM SIZES – TOP and SIDE BELT DRIVES

For applications requiring top control of difficult cases such as tall and/or narrow sizes. Manual flap folding.

- Plug-in Operation
- Dual Masts with twin lead screws for stability
- Precise Top and Bottom sealing
- Dual, Top Mounted Belt Drives for top control
- Heavy Duty Side-Belt Drives ensure square cases
- Side Mounted Compression Rollers for tight seals
- Adjustable Leg Supports
- Easy case-size change-over – two crank handles
- Piranha Tape Heads for accurate and consistent sealing

TS-654

Speed: Up to 2,400 Cases/Hour (65 fpm)
Case Length: 6" minimum – no maximum
Case Width: 6" minimum – 20" maximum
Case Height: 4.5" minimum – 20" maximum

Electrical: 110VAC-1PH-60Hz – 10 Amps
Air: None
Dimensions: 52" L x 39" W x 55-70" H
Weight: 375 lbs

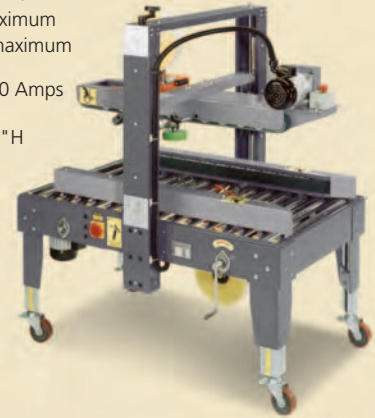

SEMI-AUTOMATIC RANDOM CASE SEALER

SR-655 – RANDOM SIZES – SIDE BELT DRIVES

Extremely versatile for applications that utilize multiple case sizes. Manual flap folding.

- Plug-in Operation
- Precise Top and Bottom sealing
- Automatic Case Height Adjustment w/ cushion
- Self Adjusting Side-Belt Drives for case-width
- Side Mounted Compression Rollers for tight seals
- Optional Swing-out Mesh Steel Guarding
- Adjustable Leg Supports
- Piranha Tape Heads for accurate and consistent sealing

SR-655

Speed: Up to 720 Cases/Hour (65 fpm)
Case Length: 6" minimum – no maximum
Case Width: 4.75" minimum – 20" maximum
Case Height: 6" minimum – 20" maximum

Electrical: 110VAC-1PH-60Hz - 10 Amps
Air: 1 SCFM @ 70 psi
Dimensions: 50" L x 38" W x 56" H
Weight: 450 lbs



Note: If the case height exceeds its length, it may not be suitable for this machine.
Capacity for larger cases. Please call or e-mail case sizes.

FULLY AUTOMATIC RANDOM CASE SEALER

SR-659 – RANDOM SIZES

For applications where multiple sized cases require closing and sealing with a single machine.

- Plug-in Operation – No operator assistance needed
- Automatic Case Height Adjustment w/ cushion
- Self Adjusting Side-Belt Drives for case-width
- Precise Top and Bottom sealing
- Front, Back and Side Flaps Automatically Folded
- Adjustable Leg Supports
- Roller top deck with photo-eye case sensors
- Piranha Tape Heads for accurate and consistent sealing
- Side Safety Mesh Steel Guarding

SR-659

Speed: Up to 300 Cases/Hour (65 fpm belt speed)
Case Length: 6" minimum – 30" maximum
Case Width: 4" minimum – 27" maximum
Case Height: 6" minimum – 20" maximum

Electrical: 110 VAC 60Hz – 20 Amps
Air: SCFM @ 70 psi
Dimensions: 79" L x 38" W x 63" H
Weight: 750 lbs

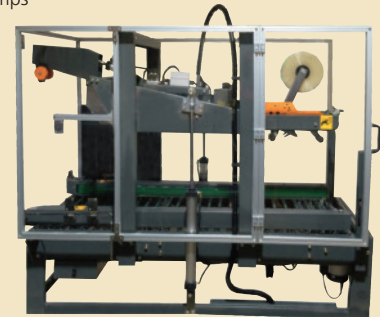

Note: If the case height exceeds its length, it may not be suitable for this machine.
Capacity for larger cases. Please call or e-mail case sizes.

SEMI-AUTOMATIC CASE ERECTOR/PACK STATION

CE-563

When connected to any Case Sealer, it enables one person to form, pack and seal corrugated cases in a single operation.

- Plug-in Operation
- Folds major flaps and holds case steady while packing
- Both Automatic and Manual Modes
- Adjustable Leg Supports
- Improve safety by eliminating costly repetitive strain injury problems
- Improve productivity and eliminate extra labor
- Moves case after packing
- Foot pedal or hand operated advancement

CE-563

Case Length: 8" minimum – 23.5" maximum
Case Width: 8" minimum – 19.5" maximum
Case Height: 4" minimum – No maximum

Air: 1 SCFM @ 70 psi
Dimensions: 57" L x 32" W x 30-39" H
Weight: 370 lbs

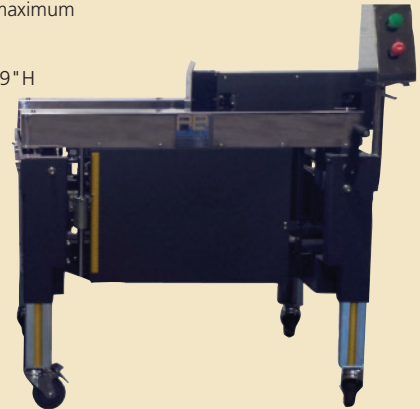

OPTIONS

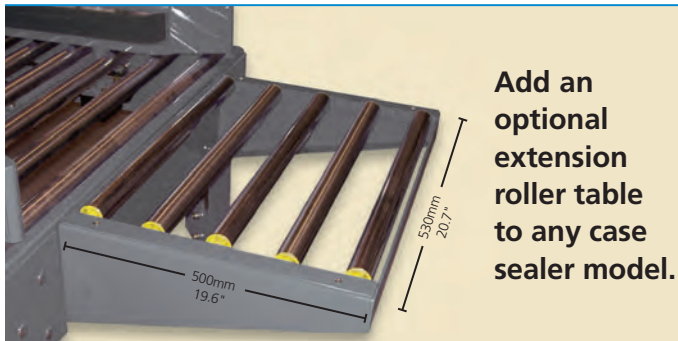

PIRANHA TAPE HEAD

- Robust and Simplistic Design
- Exact and Precise Sealing
- Professional looking packages
- Thicker Blade with deep sharp points which will cut consistently
- Single swipe seals, no wasting tape
- Also available in Stainless Steel



OUR BLADES



OTHER BLADES

Piranha

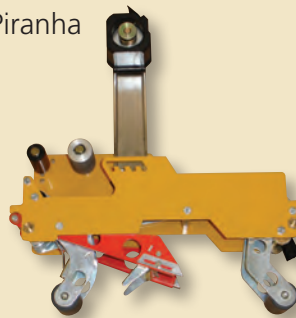

Drop-in replacements for most major brand case sealers and erectors.

The Piranha tape head is the best on the market because of its simplicity, durability and affordability.



PALCO
Industrial Marking and Labeling, Inc.
www.palcosys.com

11490 South 153rd Street • Omaha, NE 68138
Phone: (402) 556-7000 • Toll Free: (800) 255-7252 • FAX: (402) 556-6622