

 **First in Quality. Built to Last.**



# SB-2HD

## SIDE BELT CASE TAPER

### MAXIMUM UPTIME

The SB-2HD offers the quality that you have come to rely on from Easteey. The system's unique and simple design has proven to be one of the most reliable case tapers on the market today, keeping production and maintenance efforts to a minimum and providing fast and efficient alternatives to hand taping.

### WIDE STANDARD CASE RANGE

The SB-2HD's side belts are great for light or heavyweight, narrow or small boxes. The system is ideal for void fill cases where the packaged product does not support the box. SB-2HD is designed to handle boxes that most other case tapers can't.

### PRODUCTION MEETS VERSATILITY

SB-2HD offers fast and easy case changes with adjustable side rails and flexibility for boxes 4.5" long and greater. Adjustments can be made on the fly with easy hand tighten knobs and cranks. SB-2HD utilizes Easy-Taper Quick-Load top and bottom tape cartridges and will seal boxes as narrow as 4" wide and as low as 2" tall, where most standard case tapers are only able to tape at a depth of 3" or greater. The SB-2HD can be supplied to operate from left to right at no additional cost, and does not require air to run.



## INDUSTRIAL STRENGTH OPERATION

Dual drive motors and aggressive drive belts make SB-2HD a workhorse that will stand up to your toughest challenges. Each case taping machine is made from 12 gauge steel that will withstand even the most rugged applications.

### INDUSTRIAL STRENGTH OPERATION

Dual drive motors and aggressive industrial strength drive belts make SB-2HD a workhorse that will stand up to your toughest challenges. Each case taping machine is made from 12 gauge steel that will withstand even the most rugged applications. A powder coated exterior protects the machine from abusive conditions and guarantees years of use.

### CASE TAPING MADE EASY

SB-2HD is designed and built with the customer in mind. Top and bottom tape heads are interchangeable and tip back for easy threading. These machines accept 2" wide pressure-sensitive tape as a standard, or they can be ordered to handle 3" tape. The use of Easteey's SB-2HD case taping machine can be learned in minutes, avoiding breaks in production and downtime, saving your company money and increasing your ROI.

### THE RIGHT SOLUTION

Rugged design. Proven reliability. Simple operation. Your benefits go on and on. When it comes to industrial operation, rely on Easteey to provide the right solution for your case sealing needs.

# SB-2HD SIDE BELT CASE TAPER

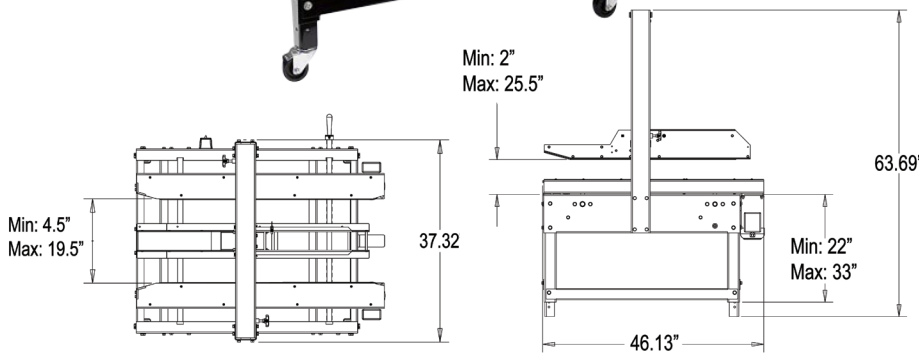
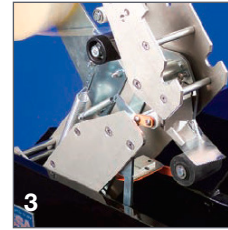
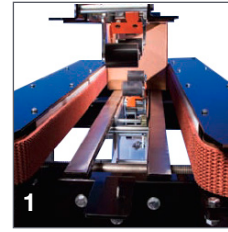

1. Industrial strength drive belts move boxes consistently through the taper
2. Adjustable side rails and tape head offer fast and easy case changes
3. Top and bottom tape heads are interchangeable and tip back for easy threading
4. Top and bottom tapeheads are identical and can be removed instantly without tools. Choose from two options.

SB-2HD FEATURES	SB-2HD TAPING SPECIFICATIONS			
<ul style="list-style-type: none"> <li>• Plug-in and go operation</li> <li>• Powder coated 12 gauge steel</li> <li>• Interchangeable top and bottom tape cartridges</li> <li>• Industrial strength side belts</li> <li>• Adjustable leg extensions</li> <li>• Fast and easy box size changes</li> <li>• No air required</li> <li>• Low maintenance</li> <li>• Accommodates wide box size change</li> </ul>	Sealer Type	Side belt, top and bottom case sealer		
	Machinery Makeup	Industrial strength 12 gauge steel, powder coated for durability		
	Belt Speed	72 feet/per minute		
	Tape Speed	30 cases/per minute, depending on box size and operator efficiency		
	Height Adjustment	Standard adjustable legs for 22.5" to 30.5" conveyor heights		
	BOX SPECIFICATIONS	Length	Width	Depth
	Minimum Box Size	4.5"	4.0"	2.0"
	Maximum Box Size	Infinite	20"	25.5"
	Tape Size	2" wide pressure sensitive tape, up to 15" diameter rolls, optional 3" wide tape		
	Tape Cartridge	Proven design requires no lubrication, tips back for simple tape threading, removable for maintenance and interchangeable with top or bottom cartridges		
Air Requirements	None			
Electrical Requirements	110 VAC, 60Hz, 5.0A			
SB-2HD OPTIONAL ACCESSORIES				
Front Packing Table	Solid table bolts before taping system to allow for case packing			
Casters	Rugged wheels for transportation within plant			
Top Squeezers	Designed to stabilize the box and push the top flaps together for easier taping			
Stainless Finish	Complete stainless finish to meet specific application requirements			

