

 **First in Quality. Built to Last.**



BB-2/SS

STAINLESS BOTTOM BELT CASE TAPER

EASTEY DELIVERS WHAT YOU NEED. . TODAY

Easteey's BB-2/SS case taper is a cost-effective top and bottom case taper designed for large run case sealing. BB-2/SS utilizes pressure-sensitive tape and features self-centering side rails, a rugged bottom belt drive, and heavy-duty mast that easily adjusts to handle a variety of case sizes. BB-2/SS is ideal for washdown conditions.

INNOVATIVE TECHNOLOGY, PROVEN RELIABILITY

BB-2/SS offers the durability, versatility and reliability that you have come to rely on from Easteey. The system's unique and simple design has proven to be one of the most reliable case tapers on the market today, keeping production and maintenance efforts to a minimum and providing fast and efficient alternatives to hand taping.

TRUE VERSATILITY FOR YOUR NEEDS

BB-2/SS offers fast and easy case changes with adjustable side rails and flexibility ranging from 4.5" to infinite box length. BB-2/SS is also able to seal cases ranging from 4.5" to 22.5" in width, as well as 4" to 25.5" in depth. Adjustments can be made on the fly with easy hand tighten knobs on a single mast design. A single drive motor and aggressive drive belts will move your boxes and stand up to your toughest challenges. BB-2/SS is also perfect for integration with ink jet printers where coding is required on boxes.

IDEAL FOR WASHDOWN CONDITIONS

Stainless steel construction coupled with a single drive washdown motor and aggressive drive belts make BB-2/SS ideal for wash down conditions.

CASE TAPING AS EASY AS 1-2-3

BB-2/SS top and bottom tape heads are interchangeable and tip back for easy threading. No air is required to run the BB-2/SS taping system so it can be placed anywhere in the factory. A safe single mast allows clear access to all components and adjusts for a variety of case sizes. The use of Easteey's BB-2/SS case taping machine can be learned in minutes, avoiding breaks in production and downtime, saving your company money and increasing your ROI.

INDUSTRIAL STRENGTH OPERATION

A washdown rated motor, with an IP65 rated switch, and industrial strength drive belts make BB-2/SS a workhorse ideal for food applications or other washdown environments. Each case taping machine is made from 12 gauge stainless steel to protect from outside chemical damage guaranteeing years of use while withstanding abusive conditions to provide high quality case sealing.

THE RIGHT SOLUTION

Rugged design. Proven reliability. Simple operation. Your benefits go on and on. When it comes to industrial operation, rely on Easteey to provide the right solution for your case sealing needs.

BB-2/SS STAINLESS BOTTOM BELT CASE TAPER

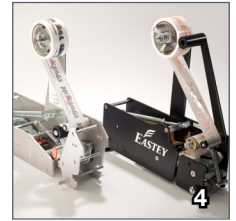
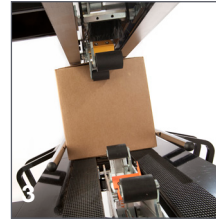
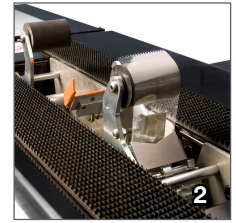
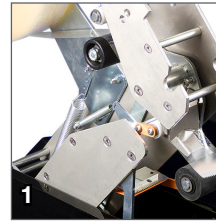
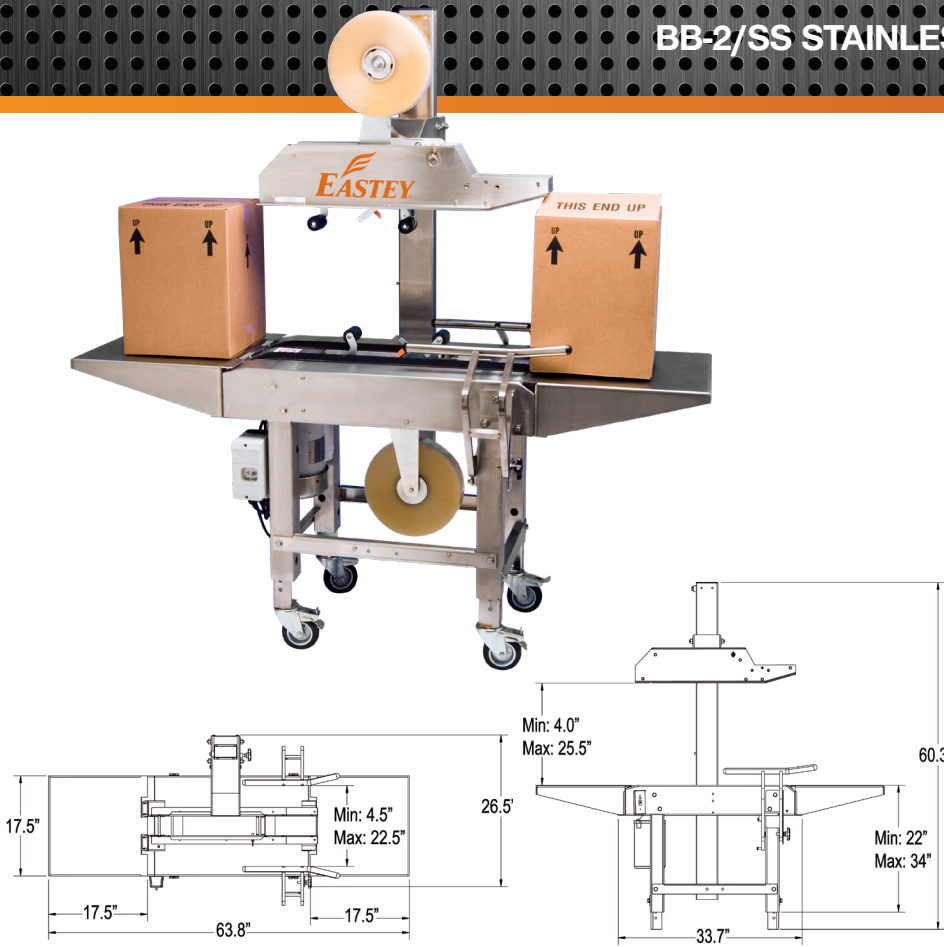

1. Top and bottom tape heads are interchangeable and tip back for easy threading
2. Industrial strength drive belts move boxes consistently through the taper
3. BB-2/SS can be easily integrated with inkjet printers
4. Top and bottom tapeheads are identical and can be removed instantly without tools. Choose from two options.

| BB-2/SS FEATURES | BB-2/SS TAPING SPECIFICATIONS | | | | |
|--|---|--|--------------|--------------|--|
| <ul style="list-style-type: none"> • Plug-in and go operation • 12 gauge stainless steel • Interchangeable top and bottom tape cartridges • Adjustable side rails • Industrial strength drive belts • Safe single mast design • Easy hand-tighten adjustments • No air required • Low maintenance • Simple integration with ink jet printers • Washdown motor and electronics • 1 pack table | Sealer Type | Bottom belt, top and bottom case sealer | | | |
| | Machinery Makeup | Industrial strength 12 gauge stainless steel | | | |
| | Belt Speed | 60 feet/per minute | | | |
| | Tape Speed | 30 cases/per minute, depending on box size and operator efficiency | | | |
| | Adjustable Side Rails | Palm grip knobs offer quick and simple adjustments | | | |
| | Height Adjustment | Standard adjustable legs for 22.25" to 34.25" conveyor heights | | | |
| | BOX SPECIFICATIONS | Length | Width | Depth | |
| | Minimum Box Size | 4.5" | 4.5" | 4" | |
| | Maximum Box Size | Infinite | 22.5" | 25.5" | |
| | Tape Size | 2" wide pressure sensitive tape, up to 15" diameter rolls, optional 3" wide tape | | | |
| Tape Cartridge | Proven design requires no lubrication, tips back for simple tape threading, removable for maintenance and interchangeable with top or bottom cartridges | | | | |
| Air Requirements | None | | | | |
| Electrical Requirements | 110 VAC, 60Hz, 10A | | | | |
| BB-2/SS OPTIONAL ACCESSORIES | | | | | |
| 3" Tape Head | Accepts 3" wide tape rolls | | | | |
| Casters | Rugged wheels for transportation within plant | | | | |
| Front and Rear Packing Table | Solid tables bolt before and/or after taping system to allow for case packing | | | | |
| Top Squeezers | Designed to stabilize the box and push the top flaps together for easier taping | | | | |

