



Engineering labeling solutions.



**PALCO**

Industrial Marking and Labeling, Inc.

[www.palcosys.com](http://www.palcosys.com)

11490 South 153rd Street • Omaha, NE 68138  
PH: (402) 556-7000 • TF: (800) 255-7252 • FAX: (402) 556-6622



**UNIVERSAL**  
labeling systems

# EVERYTHING WE ARE GOES INTO EVERYTHING WE DO.

We are labeling machinery. Since 1984, at Universal Labeling Systems, it's all we do.

We are a premier designer and builder of pressure sensitive labeling machinery. No one designs and builds more custom, made-to-order labeling machines than ULS. All labeling machines are designed and built in the USA at our St. Petersburg, Florida facility. Your labeler is sold and supported through a worldwide network of authorized distributors.

From low volume table top labeling machines to high volume zero down time labeling systems, our labelers are designed, manufactured, and tested with one purpose in mind... you and your labeling machinery needs.

And at Universal, we do more than talk as our Performance Guarantee states:

"All labeling machines manufactured by Universal Labeling Systems carries a 30-day performance guarantee. If your labeling machine does not perform as stated, we will take your machine back and reimburse you in full." Since 1984, we continue to honor this pledge.



Engineering  
Labeling Solutions.

# LABEL APPLICATORS

## SL1500 Wipe-on Applicator

- High performance Stepper motor
- Digital control package
- Multi-level menu
- Label dispense speed up to: 1500 ipm
- Web capacity: 6.25"
- Photoelectric label sensor
- 12" diameter label supply, 3" I.D. core
- Adjustable peeler bar assembly



## SL2000 High-Speed Wipe-on Applicator

- High performance Stepper motor
- Digital control package
- Multi-level operator menu
- Label dispense speed up to 3000 ipm
- 6.25" web capacity
- Photoelectric label sensor
- 16" roll capacity, 3" core
- Adjustable peeler bar assembly

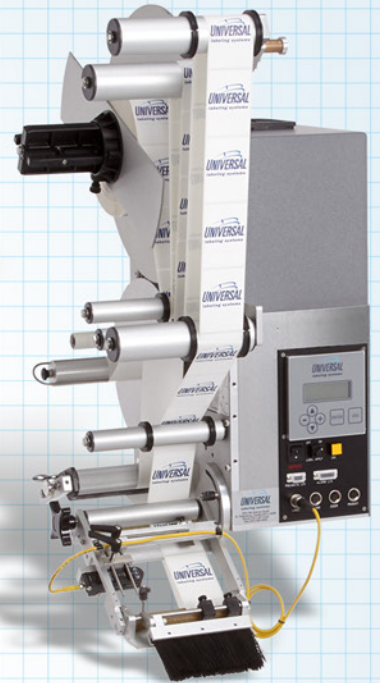
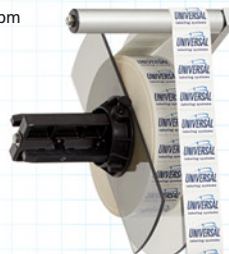

## L60 Tamp Label Applicator

- Stepper driven
- Touchscreen operator interface
- PLC controlled
- Tamp/tamp-blow
- "Quick change" tamp heads
- Photoelectric label sensor
- Label dispense speed up to 600 ipm
- Label roll capacity: 12" Ø
- Web width: 6.5"



## L15 Wipe-On Applicator

- Stepper driven
- Touchscreen operator interface
- PLC controlled
- Label dispense speed up to 1300 ipm
- 6.5" wide web capacity
- Photoelectric label sensor
- Product detection delay (ON delay)
- Label stop delay (OFF delay)
- Product counter
- 12" roll capacity, 3" core



## L30 Wipe-On Applicator

- Stepper driven
- Touchscreen operator interface
- PLC controlled
- Label dispense speed up to 800 ipm
- 2.625" wide web capacity
- Photoelectric label sensor
- Product detection delay (ON delay)
- Label stop delay (OFF delay)
- Product counter
- 10" roll capacity, 3" core

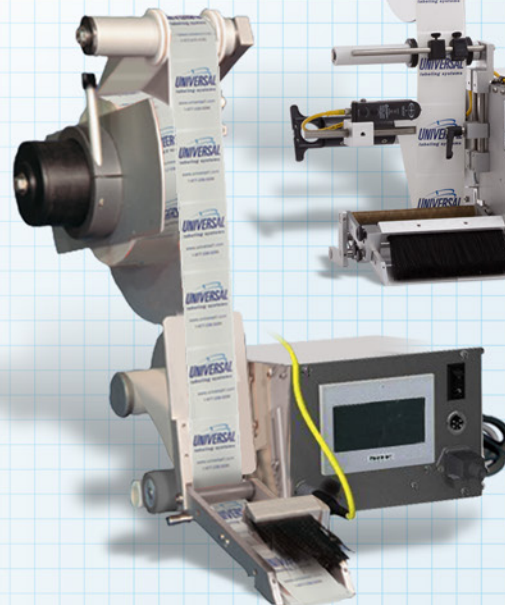

# INLINE LABELING SYSTEMS

## CP2000 Front & Back Contract Packager System

- Heavy-duty system framework
- 6" wide x 12' long Delrin chain conveyor
- All AC drives
- Product metering wheel
- Synchronous product positioning device
- Synchronous overhead hold down
- Photoelectric product sensor
- Two high-speed SL 2000 stepper driven label applicators
- Label dispense speed up to 3000 ipm
- Encoder with speed following control
- Secondary label wipe-down devices
- 6.25" wide web capacity
- 16" label roll capacity 3" core
- Job save option
- UL certified NEMA 12 control enclosure with multi-level menu system

## CP1000 Front & Back Contract Packager System

- Heavy-duty system framework
- 6" wide x 12' long Delrin chain conveyor
- All AC drives
- Product metering wheel
- Synchronous product positioning device
- Synchronous overhead hold down
- Photoelectric product sensor
- Two SL 1500 stepper-driven label applicators
- Label dispense speed up to 1500 ipm
- Encoder with speed following control
- Secondary label wipe-down devices
- 6.25" wide web capacity
- 12" label roll capacity 3" core
- Job save option
- UL certified NEMA 12 control enclosure with multi-level menu system

## R322 High-Speed Round Product System

- Heavy-duty system framework
- 6" wide x 8' long Delrin chain conveyor
- All AC drives
- Product metering wheel
- Photoelectric product sensor
- High-speed SL 2000 stepper driven label applicator
- Encoder with speed following from wrap station to SL2000
- 6.25" wide web capacity
- 16" label roll capacity 3" core
- Label dispense speed up to 3000 ipm
- 15" long label wrapping station
- Job save option
- UL certified NEMA 12 control enclosure with multi-level menu system

## R321 Round Product System

- Heavy-duty system framework
- 6" wide x 6' long Delrin chain conveyor
- All AC drives
- Product metering wheel
- Photoelectric product sensor
- SL1500 stepper driven label applicator with digital controls
- Encoder with speed following from wrap station to SL1500
- 6.25" wide web capacity
- 12" label roll capacity, 3" core
- Label dispense speed up to 1500 ipm
- 15" long label wrapping station
- Job save option
- UL certified NEMA 12 control enclosure with multi-level menu system

## R320 Round Product System

- Heavy-duty system framework
- 6" wide x 6' long Delrin chain conveyor
- All AC drives
- Product metering wheel
- Photoelectric product sensor
- L15 stepper driven label applicator
- 6.5" wide web capacity
- 12" label roll capacity, 3" core
- Label dispense speed up to 1300 ipm
- 15" long label wrapping station
- UL certified NEMA 12 control enclosure

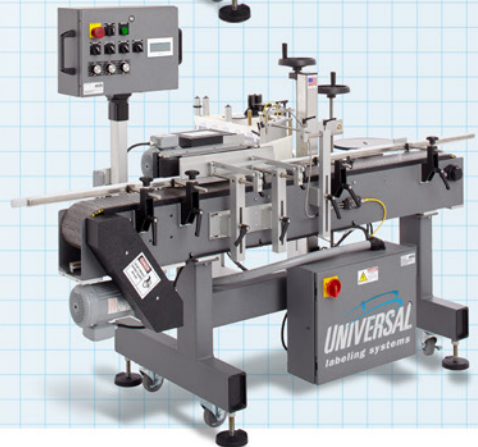
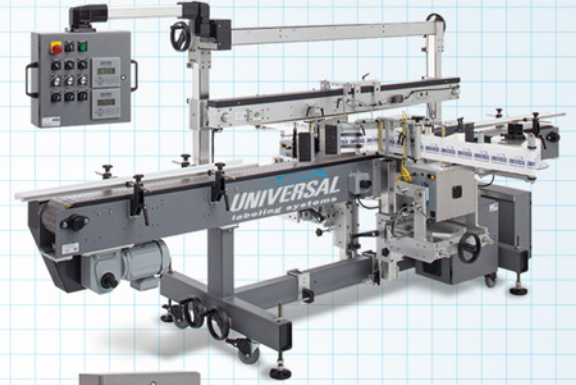
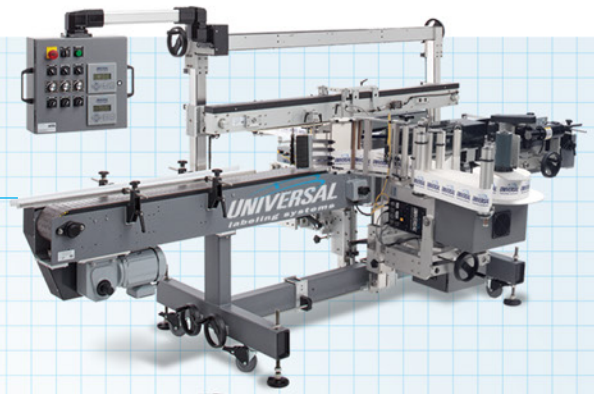

# NOW YOU HAVE A REAL CHOICE IN PRINT & APPLY LABELING.

## PNEUMATIC

### UPA II Features:

- Industrial strength Print & Apply
- Easy-to-use operator touchscreen
- Programmable Logic Controller (PLC)
- "Quick change" Tamp head
- Removable tamp head assembly for easy access to print engine.
- Proximity sensor in head "smart head"
- Label out condition
- Label roll capacity: 12" Ø
- Bar code compatible / RFID ready

### UPA II Options:

- Label on head detection
- 3-tier light tree with system fault indicators to include label low, ribbon low, and ribbon out conditions
- External signal output
- Allen Bradley Micro 850 PLC
- Tamp/blow applicator
- Wipe-on applicator
- Radio Frequency Identification (RFID)
- UPA IIe all electric (stepper driven)

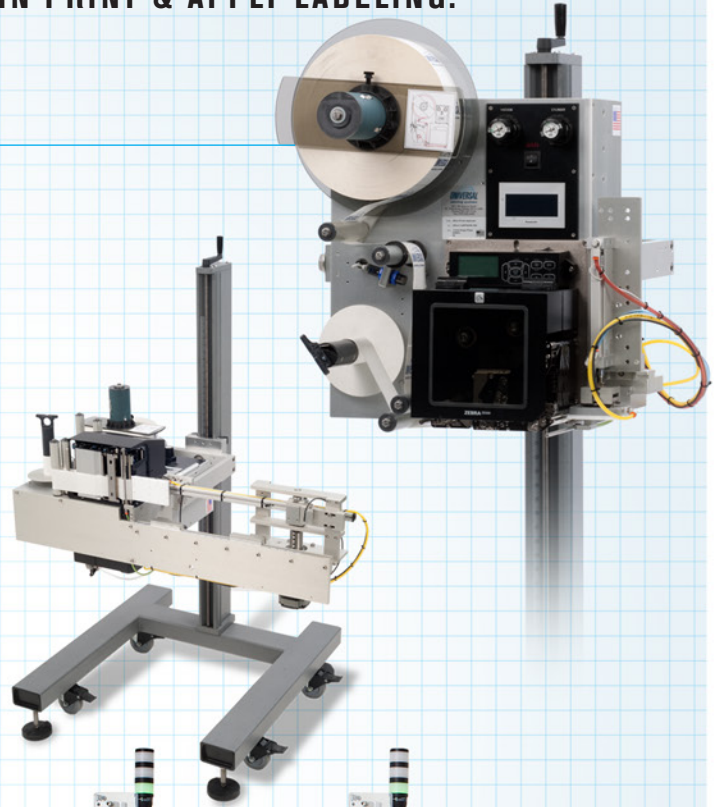

## ALL ELECTRIC

### UPA II Additional Features:

- Energy saving all electric system
- 25% faster than that of pneumatic print & apply
- Rugged industrial components with *no fans*
- Electronically adjusted stroke cylinder up to 14"



### UPA II Corner Leading (CL) and CornerTrailing (CT)

- Programmable Logic Controller (PLC) operational interface
- Swing arm or pneumatic wipe down mechanism
- Heavy duty U or T base stand
- Multiple swing arm options based on your application

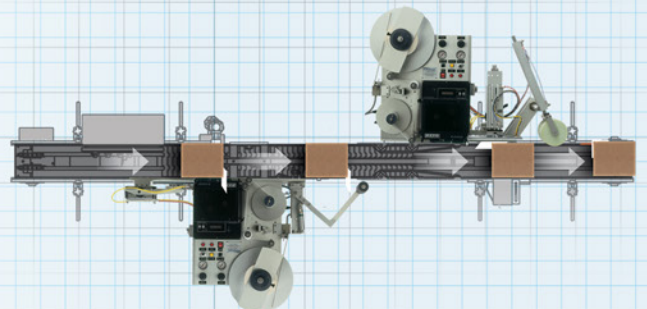

## TABLE TOP LABELING SYSTEMS

### R310 Semi-automatic Round Product Labeling System

- Stepper driven
- Single or front & back labeling
- Adjustable product carriage .375" - 6" diam.
- Photoelectric label sensor
- "Roaming peeler"
- 6.75" wide web capacity
- .625" minimum label length required
- 12" roll capacity, 3" core
- Product counter
- Foot switch activation

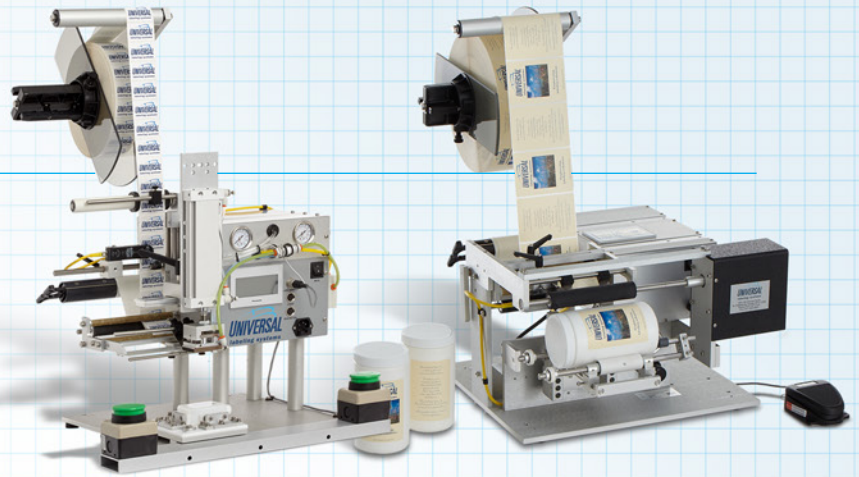

### L60 Semi-Automatic Tamp System

- Stepper Driven
- Programmable Logic Controller (PLC)
- Label dispense speed up to 600 ipm
- Photoelectric label sensor
- Tamp dwell control
- 6.5" wide web capacity
- Product detection delay (ON delay)
- Label stop delay (OFF delay)
- 12" roll capacity 3" core
- Includes one "quick change" Tamp head
- Foot switch activation

## ACCESSORIES



### C205 Hot Stamp Imprinter

- 1.25" by 1.5" imprint area
- Supports industry standard type
- Includes spacer set
- Rotate type inside holder
- Can be integrated with all Universal labeling applicators & systems

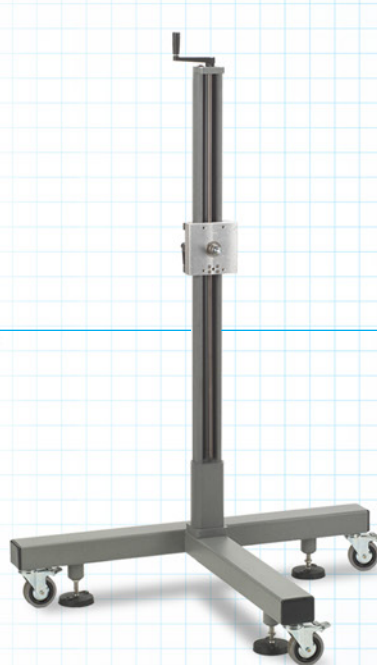

### Heavy Duty T-Base Stand

- Vertical height adjustment
- 4" diameter locking casters
- Leveling pads
- Includes L Bracket for L15-S, L30, L60 & SL1500 or Yoke Mount for SL2000 & UPA Series

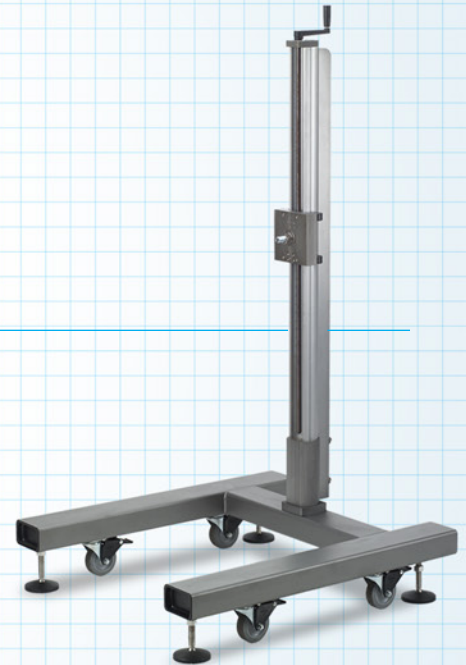

### Heavy Duty U-Base Stand

- Vertical height adjustment
- 4" diameter locking casters
- Leveling pads
- Includes L Bracket for L15-S, L30, L60 & SL1500 or Yoke Mount for SL2000 & UPA Series



### 36" or 48" Feeder Table

- (FDA approved HDPE high-density polyethylene)
- Adjustable table height to match your conveyor
- Feeder assembly
- Adjustable guide rails for various size products
- Heavy duty swivel casters and leveling pads
- Variable speed drive
- Reversible motor rotation
- Heavy duty powder-coated base
- Includes transfer plate

### 36" or 48" Accumulating Table

- (FDA approved HDPE high-density polyethylene)
- Adjustable table height to match your conveyor
- Heavy duty swivel casters and leveling pads
- Variable speed drive
- Reversible motor rotation
- Heavy duty powder-coated base
- Includes transfer plate



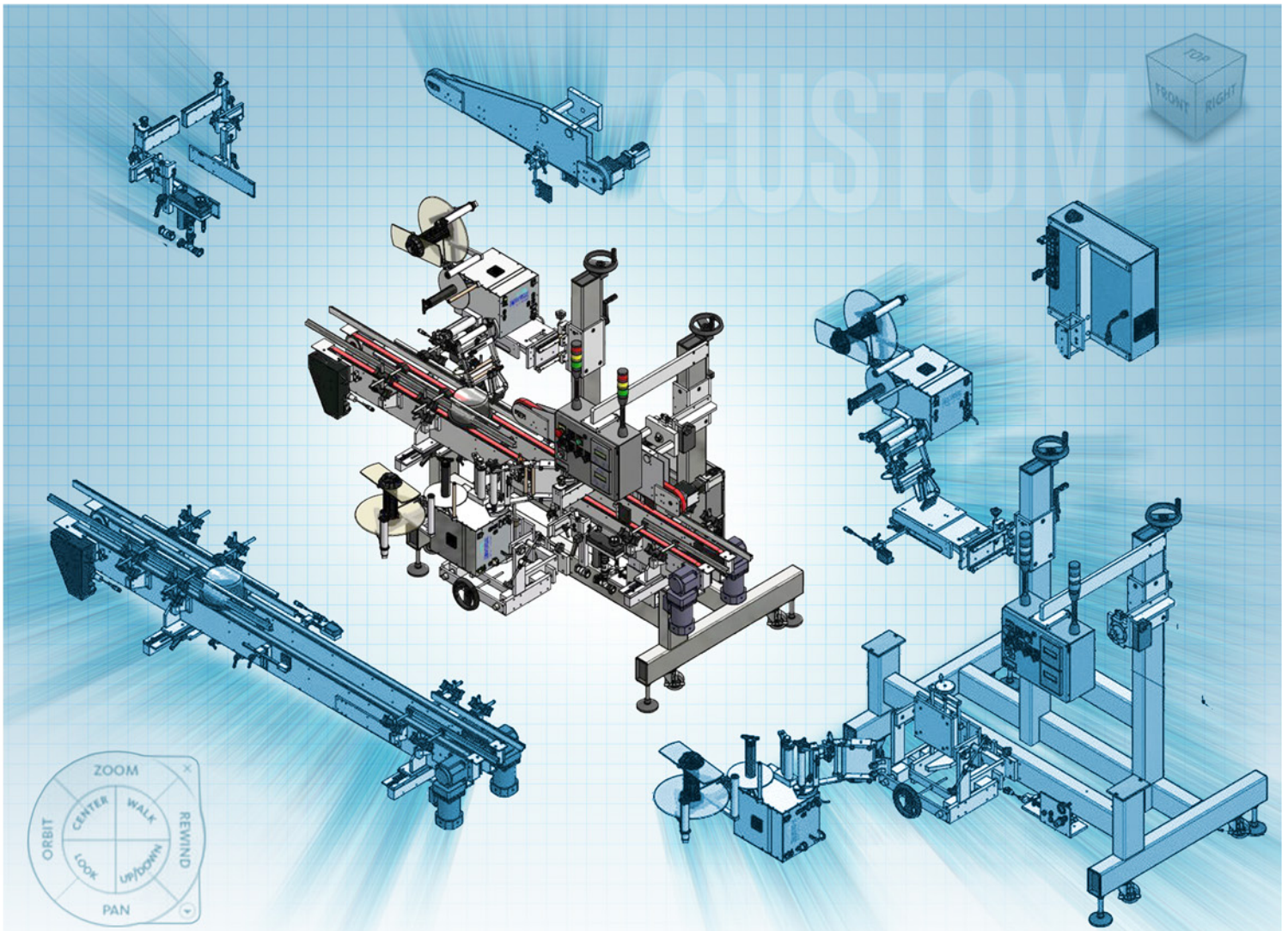

## MADE-TO-ORDER LABELING APPLICATIONS

- Automotive
- Cannabis
- Dairy / Juice
- Medical
- Bottling
- Chemicals / Cleaners
- Food / Bakery
- Pharmaceutical
- Bucket / Pail
- Craft Beer / Wine
- Health & Beauty
- Your Application

## MADE-TO-ORDER LABELING SYSTEMS



Break-Away Tamp Systems

Flag Labeling Systems

Hugger Belt Systems

Indexing Roller Systems



Interrupted Belt Systems

Multi-Panel Systems

Split Belt Systems

Tamp/Wipe Systems



Tamper Seal Systems

Vacuum Belt Systems

Vertical Trunion Systems

Zero Down Time Systems